

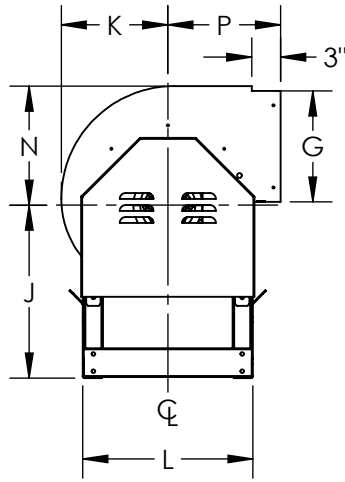

DATE: TAG:
 JOB:
 PROJECT:
 COMPANY:
 SALES PERSON:

UVS2, CLASS 1, ARRANGEMENT- 4
 UTILITY VENT SET, SIZES 60-270



DRIVE SIDE VIEW

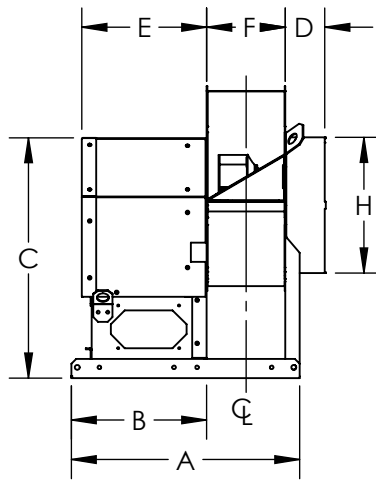

INLET VIEW

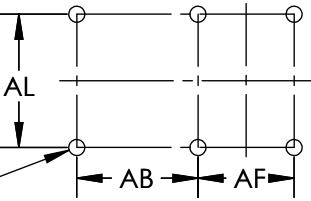

BOTTOM VIEW

STANDARD CONSTRUCTION:

1. Welded Housing
2. Steel Wheel
3. Galvanized and Bolted Pedestal
4. Slip Inlet and Outlet

OPTIONAL ACCESSORIES:

1. Weather/Motor Cover (shown in illustration)
2. Flanged Inlet and Outlet
3. Inlet/Outlet Companion Flanges
4. Vibration Isolators and Rails
5. Shaft Seal
6. Inlet/Outlet Guard
7. Piezo Ring
8. Pressure Transducer
9. Disconnect Switch
10. Spark Resistant Const. (Type B/C)

NOTES:

1. Only holes at corners are required for mounting

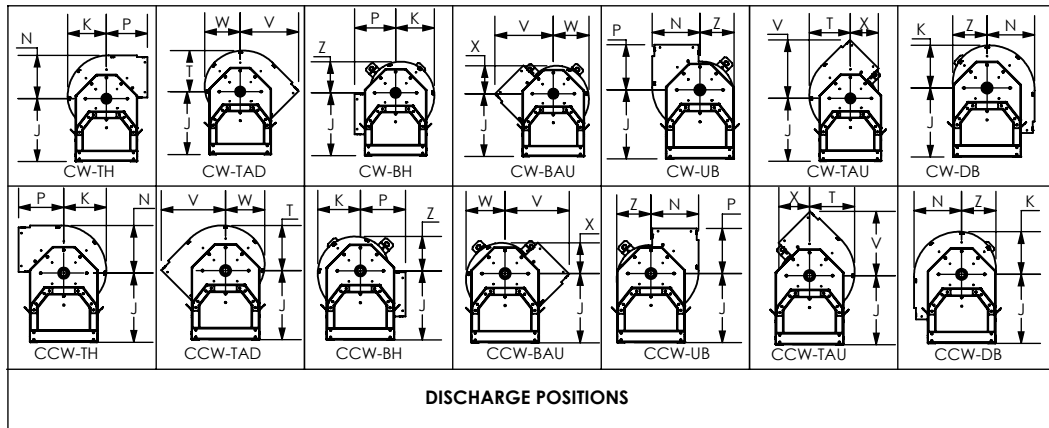

DISCHARGE POSITIONS

DIMENSIONAL DATA

SIZE	"A" (WIDTH)			B	C	D	E	"F" (WIDTH)			G	H	J	K	L	N	P	T	V	W	X	Z	AL	AB	"AF" (WIDTH)			MAX. WT. (lbs)	MAX. RPM	MAX. MTR.
	100%	80%	50%					100%	80%	50%															100%	80%	50%			
60	23.81	-	-	14.13	25.00	4.13	13.00	8.19	-	-	11.56	14.13	18.00	11.06	17.75	12.44	11.75	16.75	10.19	8.00	8.94	15.25	12.50	9.75	-	-	99	4400	145T	
70	23.81	-	-	14.13	25.00	4.13	13.00	8.19	-	-	11.56	14.13	18.00	11.06	17.75	12.44	11.75	16.75	10.19	8.00	8.94	15.25	12.50	9.75	-	-	98	4400	145T	
80	23.81	-	-	14.13	25.00	4.13	13.00	8.19	-	-	11.56	14.13	18.00	11.06	17.75	12.44	11.75	16.75	10.19	8.00	8.94	15.25	12.50	9.75	-	-	98	4400	145T	
105	23.81	-	-	14.13	25.00	4.13	13.00	8.19	-	-	11.56	14.13	18.00	11.06	17.75	12.44	11.75	16.75	10.19	8.00	8.94	15.25	12.50	9.75	-	-	96	4400	145T	
122	25.50	24.88	-	14.13	26.38	4.13	15.94	9.88	9.25	-	13.06	16.75	18.00	12.88	19.25	14.38	13.25	13.63	19.19	11.81	9.25	10.31	16.75	12.50	11.44	10.81	-	116	3550	182T
135	26.50	25.81	-	14.13	27.25	4.13	15.94	10.88	10.19	-	14.38	18.38	18.38	14.19	19.25	15.81	14.00	15.00	20.75	13.00	10.19	11.38	16.75	12.56	12.44	11.75	-	126	3222	182T
150	27.69	26.94	-	14.13	29.63	4.13	15.94	12.06	11.31	-	15.88	20.38	20.00	15.69	19.25	17.56	14.50	16.63	22.31	14.38	11.25	12.56	16.75	12.56	13.63	12.88	-	144	2900	184T
165	28.88	28.06	-	14.13	32.13	4.13	18.00	13.25	12.44	-	17.56	22.38	21.63	17.19	21.75	19.25	15.25	18.19	24.00	15.75	12.31	13.75	19.25	12.56	14.81	14.00	-	169	2636	213T
182	30.44	29.44	28.00	14.88	35.13	4.13	20.44	14.06	13.19	11.63	20.06	23.13	23.63	18.94	22.75	21.19	15.75	20.06	25.75	17.31	13.56	15.13	20.25	13.31	15.63	14.69	13.19	191	2300	213T
200	31.75	30.75	29.13	14.88	38.50	4.13	20.44	15.38	14.38	12.75	22.00	25.25	25.75	20.69	25.25	23.19	17.00	21.94	28.06	18.94	14.81	16.56	22.75	13.31	17.00	15.94	14.31	261	2100	213T
222	33.50	32.38	30.50	14.88	42.06	4.13	20.44	17.13	16.00	14.13	24.50	28.00	28.25	23.00	27.25	25.75	18.50	24.38	30.94	21.06	16.44	18.38	24.75	13.31	18.75	17.56	15.75	328	1888	215T
245	38.88	37.63	35.75	18.63	45.50	4.13	23.19	18.75	17.50	15.63	27.00	30.88	30.75	25.25	29.25	28.31	20.00	26.75	33.79	23.13	18.00	20.13	26.75	17.00	20.38	19.06	17.19	400	1714	254T
270	40.75	39.50	37.25	18.63	49.63	4.13	23.19	20.63	19.38	17.13	29.75	33.88	33.75	27.75	32.75	31.13	22.00	29.44	37.25	25.44	19.81	22.13	30.25	17.00	22.25	21.00	18.69	466	1556	254T

ALL DIMENSIONS ARE IN INCHES, WEIGHTS ARE APPROXIMATE AND DOES NOT INCLUDE DRIVES OR ACCESSORIES.

REVISION:

FORM:

REPLACES:



DATE: TAG:
 JOB:
 PROJECT:
 COMPANY:
 SALES PERSON:

UVS2, CLASS 1, ARRANGEMENT- 4
 UTILITY VENT SET, SIZES 300-330

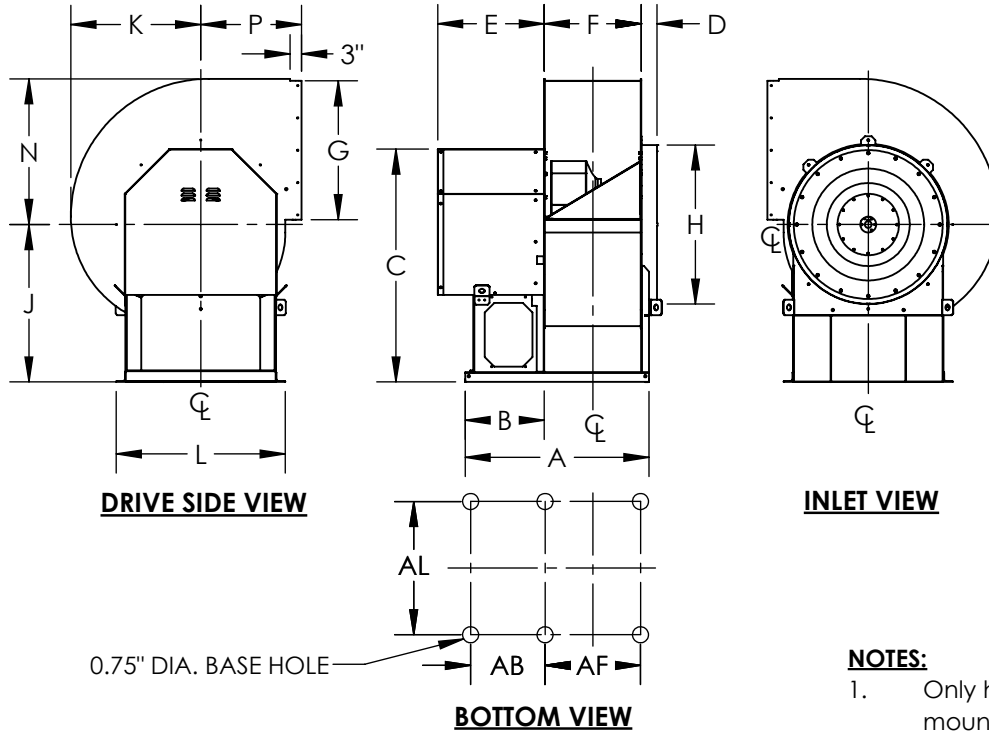

STANDARD CONSTRUCTION:

1. Welded Housing
2. Steel Wheel
3. Galvanized and Bolted Pedestal
4. Slip Inlet and Outlet

OPTIONAL ACCESSORIES:

1. Weather/Motor Cover (shown in illustration)
2. Flanged Inlet and Outlet
3. Inlet/Outlet Companion Flanges
4. Vibration Isolators and Rails
5. Shaft Seal
6. Inlet/Outlet Guard
7. Piezo Ring
8. Pressure Transducer
9. Disconnect Switch
10. Spark Resistant Const. (Type B/C)

NOTES:

1. Only holes at corners are required for mounting

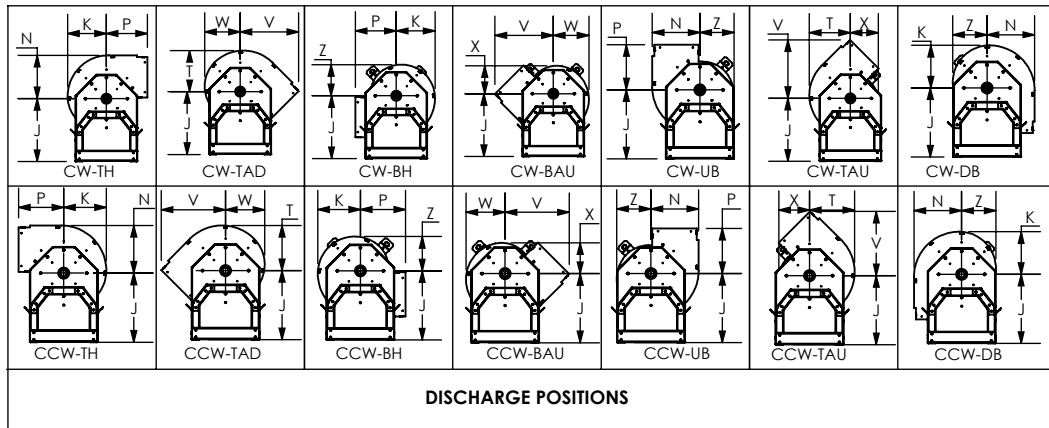

DIMENSIONAL DATA

SIZE	"A" (WIDTH)			B	C	D	E	"F" (WIDTH)			G	H	J	K	L	N	P	T	V	W	X	Z	AL	AB	"AF" (WIDTH)			MAX. WT. (lbs)	MAX. RPM	MAX. MTR
	100%	80%	50%					100%	80%	50%															100%	80%	50%			
300	45.63	44.13	41.75	20.63	55.44	4.13	23.19	23.00	21.50	19.13	32.88	37.69	37.63	30.81	40.50	34.56	23.88	32.69	41.00	28.25	22.00	24.63	38.50	18.63	24.00	22.50	20.13	678	1400	256T
330	47.88	46.25	43.63	20.63	60.63	4.13	27.75	25.25	23.63	21.00	36.19	41.44	41.00	33.81	44.00	37.94	26.25	35.88	45.00	30.94	24.13	27.00	42.00	18.63	26.25	24.63	22.00	811	1273	286T

ALL DIMENSIONS ARE IN INCHES, WEIGHTS ARE APPROXIMATE AND DOES NOT INCLUDE DRIVES OR ACCESSORIES.

REVISION:

FORM:

REPLACES: